



Unsurpassed solutions



MAGNETIC LIFTING SYSTEMS

UNSURPASSED magnetic material handling solutions

CONTENTS

- 03 HPA Scrap handling up to 4600 kg
- 04 HPD Plate handling up to 4000kg X 4m plates with On/off on board
- 05 HPC Plate handling up to 4000kg X 4m plates with on board controls
- 06 HPB Battery operated electro-perm up to 3000kg X 3m
- 07 HPT Plate handling up to 20000kg X 6.1m
- 09 HPS Slab and block handling up to 30000kg X 6.1m
- 11 HPM Plate handling up to 25000kg X 16m
- 13 HPR Round stock handling up to 3000kg X 8m
- 15 HPE Battery powered electro magnet 5000kg X 1.5m
- 16 PLN Confined space lifter up to 1000kg X 3m
- 17 SAFER General purpose permanent lifter up to 5000kg X 4m
- 18 SAFER-T Thin stock handling up to 1000kg X 3m
- 19 SAFER-R Round stock handling up to 3000kg X 3.5m
- 20 PAR Vertical loads
- 21 BLM Spreader bars
- 22 NLT Pneumatic operated



■ Helmholtz lifting magnets are BTH-1 and B30.20 compliant



■ All magnetic performances are directly related to the actual size and shape



MAGNETIC LIFTING SYSTEMS

Soph offers the most comprehensive package of magnetic solutions for workholding, mold and die clamping and material handling. Starting the business in 1998, until now Soph owns the trademarks and business of Brisc, Magbo and Helmholtz which is for workholding, mold and die clamping and material handling respectively. Based in Hamburg Germany, after years of development, Soph now has branches in USA and China.

Soph Ltd installed a mfg Facility in Fenton MI 2019. Coupled with one of the largest finished product inventories, highly skilled service and sales engineers, Soph has created a substantial reference base in Europe, North America and Far east in a relatively short time. Our ability to provide immediate technical answers, immediate service, custom design, OEM specific products and product lines keeps us ahead of the curve.

With creative problem solving and application specific solutions, Soph is considered to be one of the finest sources for magnetic solutions available. We are dedicated to provide the best product with the best performance to match each application. By using customer input we are able to provide tailor made solutions using standardized products to create unmatched value in substantially shorter market cycles.



HPA

ELECTROMAGNETIC LIFTER

High power electro-magnets for scrap related processing operations

Features

- 75% duty cycle for maximum lifting performance throughout and entire shift
- Deep field construction
- Welded manganese bottom plate for durability
- B30.20 and BTH-1 compliant
- External lead with quick disconnect
- Alloy steel chains for maximum durability
- High power to weight ratio
- 230VDC

Applications

- Scrap yards
- Steel mills
- Special designed applications with multiple magnets and automated controls
- Recycling yards
- Plate shops



Dimensions

mm(inch)

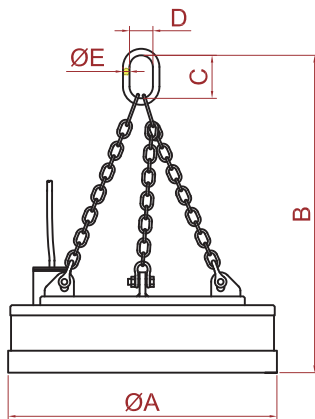

Model	Size	B	C	D	E
HPA	8	780 (30.7)	140 (5.5)	90 (3.5)	28 (1.1)
HPA	9	1085 (42.7)	175 (6.9)	125 (4.9)	38 (1.5)
HPA	11	1270 (50.0)	220 (8.7)	150 (5.9)	45 (1.8)
HPA	13	1290 (50.8)	250 (9.8)	175 (6.9)	50 (2.0)
HPA	15	1360 (53.5)	350 (13.8)	210 (8.3)	60 (2.4)
HPA	16	1670 (65.7)	370 (14.6)	230 (9.1)	75 (3.0)
HPA	18	1600 (63.0)	370 (14.6)	230 (9.1)	75 (3.0)
HPA	21	1900 (74.8)	400 (15.7)	250 (9.8)	80 (3.1)
HPA	24	2100 (82.7)	450 (17.7)	280 (11.0)	90 (3.5)

Model	Size	Diameter	DC Voltage (V)	Amps (cold) (A)	KW	Net Weight	#1 Heavy melting	#2 Heavy melting	Turnings
HPA	8	800 (31.50)	230	12	3	620 kg / 1366 lb	480 kg / 1058 lb	150 kg / 330 lb	-
HPA	9	900 (35.43)	230	18	4	735 kg / 1620 lb	600 kg / 1322 lb	250 kg / 551 lb	-
HPA	11	1100 (43.31)	230	28	6	1500 kg / 3306 lb	1000 kg / 2204 lb	450 kg / 992 lb	150 kg / 330 lb
HPA	13	1300 (51.18)	230	41	9	2280 kg / 5026 lb	1400 kg / 3086 lb	700 kg / 1543 lb	250 kg / 551 lb
HPA	15	1500 (59.06)	230	54	11	3175 kg / 7000 lb	1900 kg / 4188 lb	1100 kg / 2425 lb	400 kg / 881 lb
HPA	16	1650 (64.96)	230	56	12	3840 kg / 8465 lb	2300 kg / 5070 lb	1300 kg / 2866 lb	500 kg / 1102 lb
HPA	18	1800 (70.87)	230	74	16	4690 kg / 10340 lb	2750 kg / 6062 lb	1600 kg / 3527 lb	600 kg / 1322 lb
HPA	21	2100 (82.68)	230	99	22	7810 kg / 17218 lb	3500 kg / 7716 lb	2200 kg / 4850 lb	900 kg / 1984 lb
HPA	24	2400 (94.49)	230	118	26	10115 kg / 22300 lb	4600 kg / 10141 lb	2850 kg / 6283 lb	1300 kg / 2866 lb

HPD

LIFTING MAGNET BUILT IN PUSH BUTTONS

Electro-permanent lifter with on board controls

Features

- ① Electro-permanent technology means loss of power does not drop the load
- ② On board push button make it extremely easy for the operator
- ③ Quick disconnect make it very versatile
- ④ Indicator lights show lifter status
- ⑤ Two button operation required for safety

Applications

Handling of plates, blocks, bars, finished parts

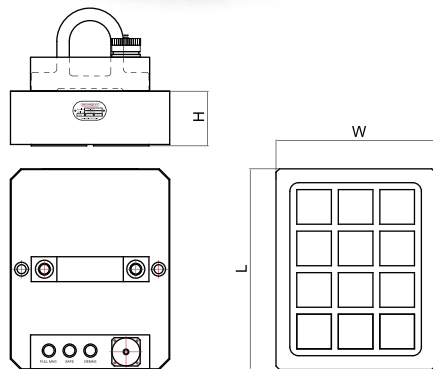

Specifications

mm(inch)

Model	Size	Length(L)	Width(W)	Height(H)	Net Weight	Flat load Max	Min thickness	Flat size Max
HPD	1000	290 (11.42)	230 (9.06)	82 (3.23)	40 kg / 90 lb	1000 kg/2200 lb	8 (0.3)	2000x1000 (78x39)
HPD	2000	410 (16.14)	230 (9.06)	82 (3.23)	58 kg / 127 lb	2000 kg/4400 lb	8 (0.3)	3050x1525 (120x60)
HPD	3000	680 (26.77)	230 (9.06)	82 (3.23)	96 kg / 210 lb	3000 kg/6600 lb	8-15 (0.3-0.6) >15 (>0.6)	3050x1525 (120x60) 4000x2000 (157x78)
HPD	4000	860 (33.86)	230 (9.06)	82 (3.23)	125 kg / 276 lb	4000 kg/8800 lb	8-15 (0.3-0.6) >15 (>0.6)	3050x1525 (120x60) 4000x2000 (157x78)

Optional beam

mm(inch)

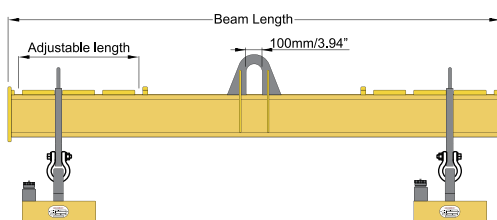

Model	Lifer Model	Beam Length	Min. Flat thickness	Max. Flat size
FBA 2000	HPD 1000	2000 (78)	8 (0.3)	3050x1000 (120x39)
FBA 3000	HPD 2000	3000 (118)	8 (0.3)	4500x1525 (177x60)
FBA 3000	HPD 3000	3000 (118)	8-15 (0.3-0.6)	4500x1525 (177x60)
FBA 4000		4000 (157.5)	>15 (>0.6)	6100x1525 (240x60)
FBA 3000	HPD 4000	3000 (118)	8-15 (0.3-0.6)	4500x1525 (177x60)
FBA 4000		4000 (157.5)	>15 (>0.6)	6100x1525 (240x60)

HPC

ELECTRO-PERMANENT LIFTER WITH CONTROLLER

Combined magnet and controller in one small package with quick disconnet

Features

- Electro-permanent technology means clamping force remains even with loss of power supply
- Built in controller make it extremely easy for the operator
- Quick connector make it very mobile
- Push button with status lights on board the magnetic module
- With reduced power pick up sequence providing safe lifts every time

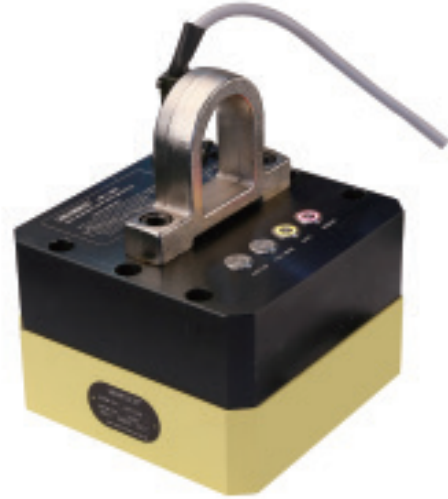

Applications

Handling of plates, blocks, bars, finished parts

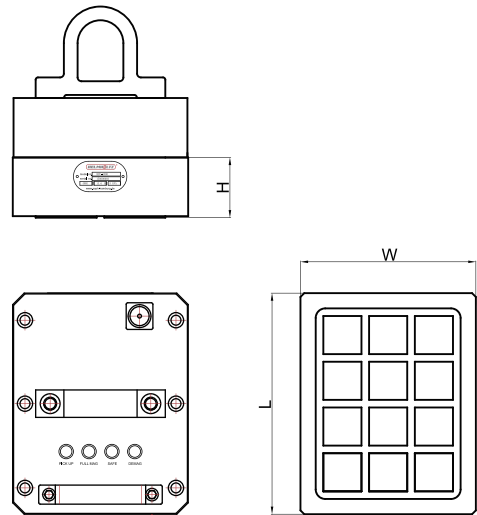
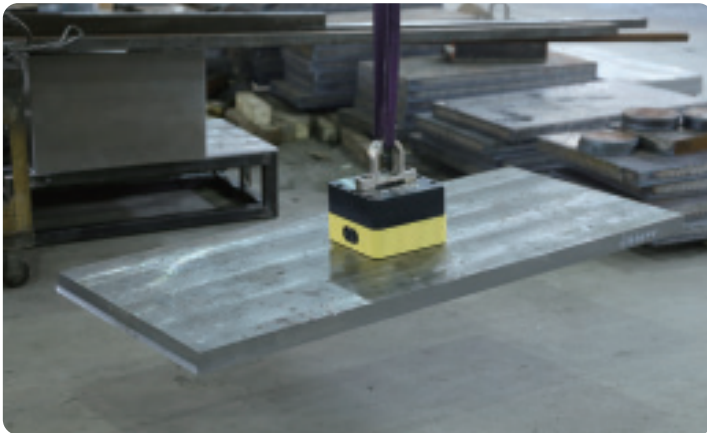

Specifications

mm(inch)

Model	Size	Length(L)	Width(W)	Height(H)	Net Weight	Flat load Max	Min thickness	Flat size Max
HPC	1000	290 (11.42)	230 (9.06)	82 (3.23)	45 kg / 99 lb	1000 kg/2200 lb	8 (0.3)	2000x1000 (78x39)
HPC	2000	410 (16.14)	230 (9.06)	82 (3.23)	63 kg / 138 lb	2000 kg/4400 lb	8 (0.3)	3000x1500 (118x59)
HPC	3000	680 (26.77)	230 (9.06)	82 (3.23)	104 kg / 228 lb	3000 kg/6600 lb	8-15 (0.3-0.6) >15 (>0.6)	3000x1500 (118x59) 4000x2000 (157x78)
HPC	4000	860 (33.86)	230 (9.06)	82 (3.23)	130 kg / 286 lb	4000 kg/8800 lb	8-15 (0.3-0.6) >15 (>0.6)	3000x1500 (118x59) 4000x2000 (157x78)

HPB

LIFTING MAGNET WITH RADIO REMOTE

These magnets are compact, mobile, self-contained using a heavy duty 12 volt battery. Operating on this battery source they are free of restrictive cords and wires. They also have the added advantage of being useful in areas where electricity is not available.

Remote control allows loading and unloading of large burn tables.

Features

- More than 600 Mag / De-mag operations without recharging the batteries. Batteries require charging once a week instead of every day so they will last longer than standard electro-magnet batteries
- With the electro-permanent design the electrical power is only required for just a few seconds to activate and deactivate the magnet. This means loss of power does not change the holding force
- If the battery is getting low, the mag / demag will be disabled and flashing light will indicate this status
- Built in battery charger can 220-240V for a 8 hours charging cycle
- Remote control distance more than 35 meters
- HSS (Helmholtz safety system) prevents De-mag while load is suspended
- Mag/De-mag can be performed by using buttons on the lifter or via wireless remote
- Heavy duty Handle/guard combo makes the lifter easy to use and tough
- Monoblock structure make the devise sturdy and maintance free

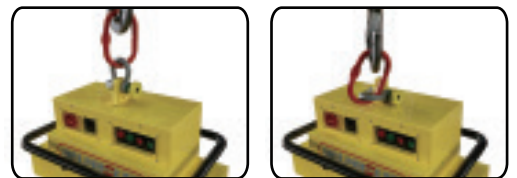

The specially designed sensor ensures the lifter can be DEMAG only when the load is well secured
HSS (Helmholtz safety system)

Applications

Handling of plates, blocks, bars, finished parts from longer distances especially useful for loading machines/burn tables

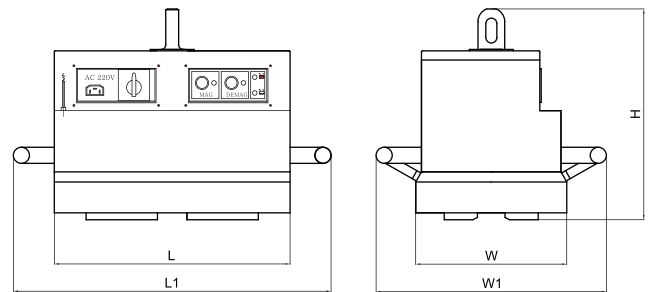

Specifications

mm(inch)

Model	Size	Safe working load	L	L1	W	W1	H	Net Weight
HPB	1500	1500 kg/3300 lb	512 (20.16)	690 (27.17)	328 (12.91)	500 (19.69)	460 (18.11)	170 kg / 374 lb
HPB	2000	2000 kg/4400 lb	512 (20.16)	690 (27.17)	328 (12.91)	500 (19.69)	460 (18.11)	180 kg / 396 lb
HPB	3000	3000 kg/6600 lb	730 (28.74)	690 (27.17)	328 (12.91)	500 (19.69)	460 (18.11)	248 kg / 545 lb

Load Capabilities

mm(inch)

Model	Size	Flat load Max	Min thickness	Flat Length Max	Round load Max	Diameter Min	Round length Max
HPB	1500	1500 kg/3300 lb	25 (0.98)	1500 (59.06)	500 kg/1100 lb	150 (5.91)	1500 (59.06)
HPB	2000	2000 kg/4400 lb	25 (0.98)	2000 (78.74)	700 kg/1540 lb	150 (5.91)	2000 (78.74)
HPB	3000	3000 kg/6600 lb	25 (0.98)	3000 (118.11)	1000 kg/2200 lb	150 (5.91)	3000 (118.11)

HPT

ELECTRO-PERMANENT LIFTER FOR PLATES AND SLABS

For handling single plates or semi finished blocks

HPT electro-permanent magnetic modules are the ideal answer for handling plates or blocks. Completely adjustable destacking down to 5 mm.

- Excellent power to weight ratio
- Multi-pole powered magnetic circuit insures no residual magnetism and high performance with a low flux depth for better versatility
- “ STEEL MILL TOUGH with 3.7” ” thick monobloc frame

Standard Safety features:

- Electro-perm technology cannot drop a load due to loss of power
- Test lift sequence prevents unsafe loads due to air-gap, load geometry, or actual load composition from being handled
- Lifter status lights to insure the operator always knows the lifter status
- Radio remote keeps the operator a safe distance while operating the magnet
- Safety switch prevents de-mag unless the load is safely on the ground
- CSS sensor to insure controller and magnet are working properly
- Safe button to prevent accidental De-mag

Standard Operational Features:

- Adjustable power level for de-stacking plates and slabs as needed
- Radio remote
- No residual magnetism
- Low flux depth
- Adjustable test lift sequence
- Status lights
- Electro perm technology saves energy
- No moving parts to wear
- On board controls for easy installation

Optional:

1. Removable poles shoes
2. Dual controls
3. Temperature sensor
4. Hi temp version available on request
5. DC power supply
6. Crane control interface
7. MSD sensor to check magnetic saturation each and every lift

Applications

Steel service centers, Mold and die shop, Fabricators, Heat treating, steel mills, Steel warehouse, Job shops



HPT

ELECTRO-PERMANENT LIFTER FOR PLATES AND SLABS

Specifications mm(inch)

Model	A	B	C	D	E	F	G	H	I	L
HPT 50	1540 (60.6)	446 (17.6)	108 (4.3)	259 (10.2)	440 (17.3)	760 (29.9)	250 (9.8)	130 (5.1)	9 (0.35)	823 (32.4)
HPT 100	1540 (60.6)	446 (17.6)	108 (4.3)	259 (10.2)	740 (29.1)	870 (34.3)	250 (9.8)	130 (5.1)	9 (0.35)	1004 (39.5)
HPT 150	1640 (64.6)	456 (18.0)	118 (4.6)	259 (10.2)	980 (38.6)	1130 (44.5)	250 (9.8)	130 (5.1)	9 (0.35)	1223 (48.1)
HPT 200	1640 (64.6)	456 (18.0)	118 (4.6)	259 (10.2)	1220 (48.0)	1350 (53.1)	270 (10.6)	140 (5.5)	9 (0.35)	1462 (57.6)

Load Capabilities mm(inch)

Model	Weight	Thickness	Width	Length		Rated lift capacity
		Min.	Max.	Min.	Max.	Max.
HPT 50	600 kg / 1320 lb	8 (0.3)	3500 (137.80)	1000 (39.37)	6100 (240.16)	5000 kg / 11000 lb
HPT 100	800 kg / 1760 lb	8 (0.3)	3500 (137.80)	1000 (39.37)	6100 (240.16)	10000 kg / 22000 lb
HPT 150	1150 kg / 2530 lb	8 (0.3)	3500 (137.80)	1000 (39.37)	6100 (240.16)	15000 kg / 33000 lb
HPT 200	1580 kg / 3480 lb	8 (0.3)	3500 (137.80)	1000 (39.37)	6100 (240.16)	20000 kg / 44000 lb

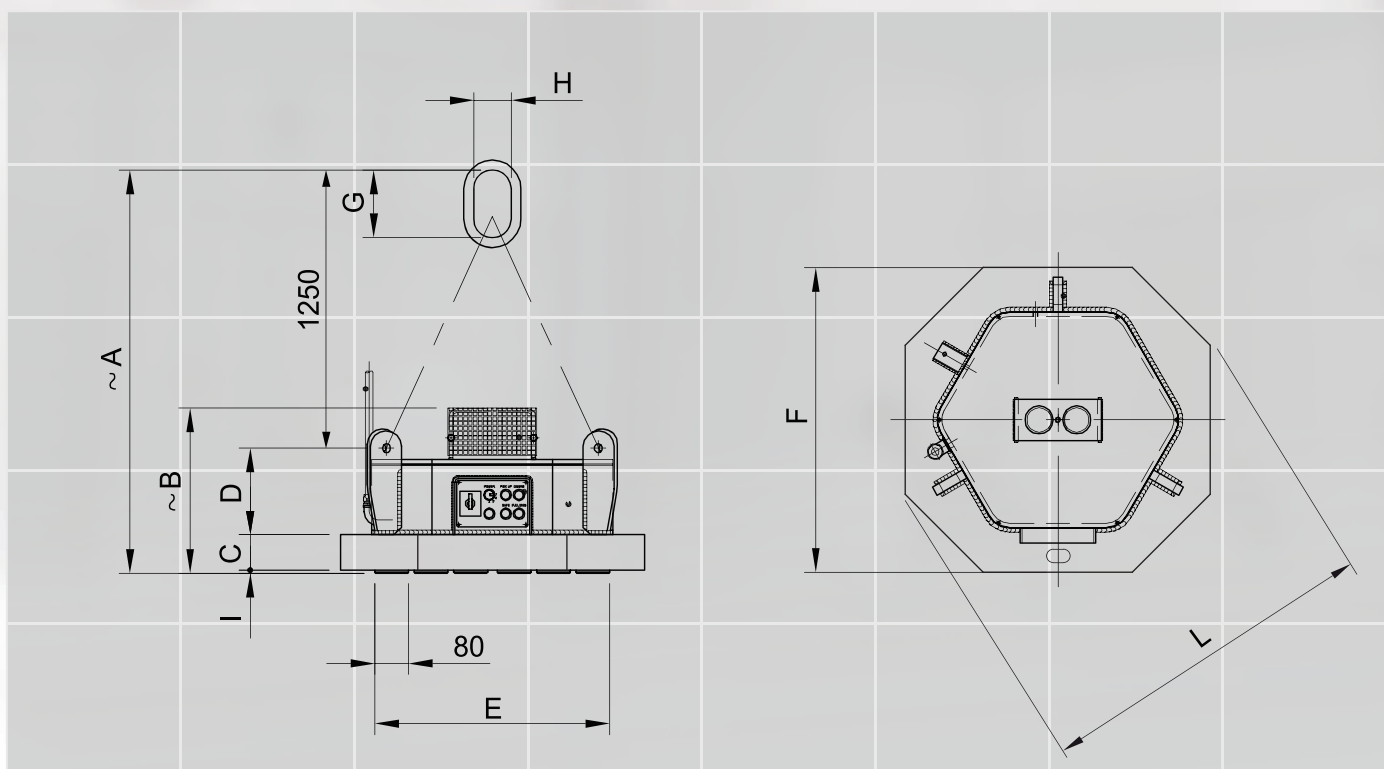
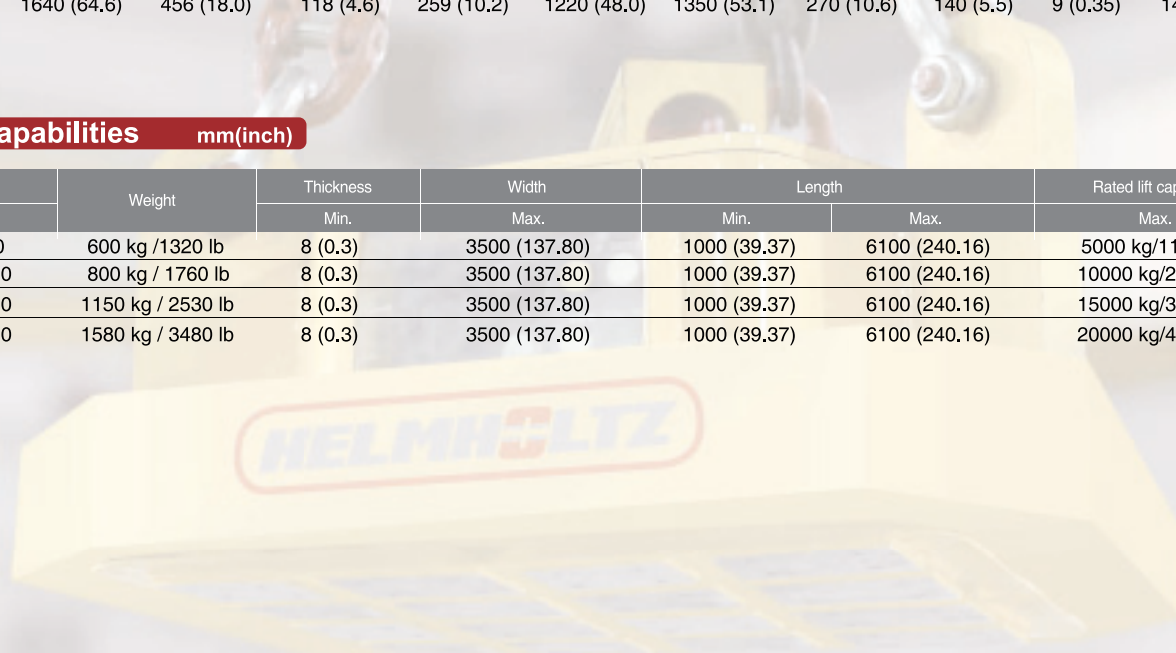

HPS

ELECTRO-PERMANENT LIFTER FOR SLAB AND BLOCK

For handling slabs and forged blocks

HPS permanent electro-magnetic modules are designed for lifting loads with large operational air gaps.

- 4-pole magnetic circuit for high force concentration.
- High magnet strength.
- “ STEEL MILL TOUGH with 3.7” ” thick monobloc frame.

Standard Safety features:

- Electro-perm technology cannot drop a load due to loss of power
- Test lift sequence prevents unsafe loads due to air-gap, load geometry, or actual load composition from being handled
- Lifter status lights to insure the operator always knows the lifter status
- Radio remote keeps the operator a safe distance while operating the magnet
- Safety switch prevents de-mag unless the load is safely on the ground
- CSS sensor to insure controller and magnet are working properly
- Safe button to prevent accidental De-mag

Standard Operational Features:

- Adjustable power level for de-stacking plates and slabs as needed
- Radio remote
- No residual magnetism
- Low flux depth
- Adjustable test lift sequence
- Status lights
- Electro perm technology saves energy
- No moving parts to wear

Optional:

1. Removable poles shoes
2. Dual controls
3. Temperature sensor
4. Hi temp version available on request
5. DC power supply
6. Crane control interface
7. MSD sensor to check magnetic saturation each and every lift

Applications

Steel service centers, Mold and die shop, Fabricators, Heat treating, steel mills, Steel warehouse, d b shops



HPS

ELECTRO-PERMANENT LIFTER FOR SLAB AND BLOCK

Specifications mm(inch)

Model	A	B	C	D	E	F	G	H	I	L
HPS 50	1820 (71.7)	645 (25.4)	285 (11.2)	190 (7.5)	460 (18.1)	760 (29.9)	250 (9.8)	130 (5.1)	17 (0.7)	822 (32.4)
HPS 100	1820 (71.7)	645 (25.4)	285 (11.2)	270 (10.6)	620 (24.4)	850 (33.5)	250 (9.8)	130 (5.1)	17 (0.7)	1024 (40.3)
HPS 150	1820 (71.7)	645 (25.4)	285 (11.2)	330 (13.0)	740 (29.1)	970 (38.2)	250 (9.8)	130 (5.1)	17 (0.7)	1180 (46.5)
HPS 200	1850 (72.8)	645 (25.4)	285 (11.2)	400 (15.7)	880 (34.6)	1110 (43.7)	270 (10.6)	140 (5.5)	17 (0.7)	1374 (54.1)
HPS 250	1850 (72.8)	647 (25.5)	290 (11.4)	450 (17.7)	980 (38.6)	1300 (51.2)	270 (10.6)	140 (5.5)	17 (0.7)	1547 (60.9)

Load Capabilities mm(inch)

Model	Weight	Thickness	Width	Length		Rated lift capacity
		Min.	Max.	Min.	Max.	Max.
HPS 50	1280 kg/2820 lb	30 (1.18)	3500 (137.80)	1000 (39.37)	6100 (240.16)	5000 kg/11000 lb
HPS 100	1760 kg/3880 lb	30 (1.18)	3500 (137.80)	1000 (39.37)	6100 (240.16)	10000 kg/22000 lb
HPS 150	2280 kg/5030 lb	40 (1.57)	3500 (137.80)	1000 (39.37)	6100 (240.16)	15000 kg/33000 lb
HPS 200	2970 kg/6550 lb	40 (1.57)	3500 (137.80)	1000 (39.37)	6100 (240.16)	20000 kg/44000 lb
HPS 250	4000 kg/8820 lb	80 (3.15)	3500 (137.80)	1000 (39.37)	6100 (240.16)	25000 kg/55000 lb

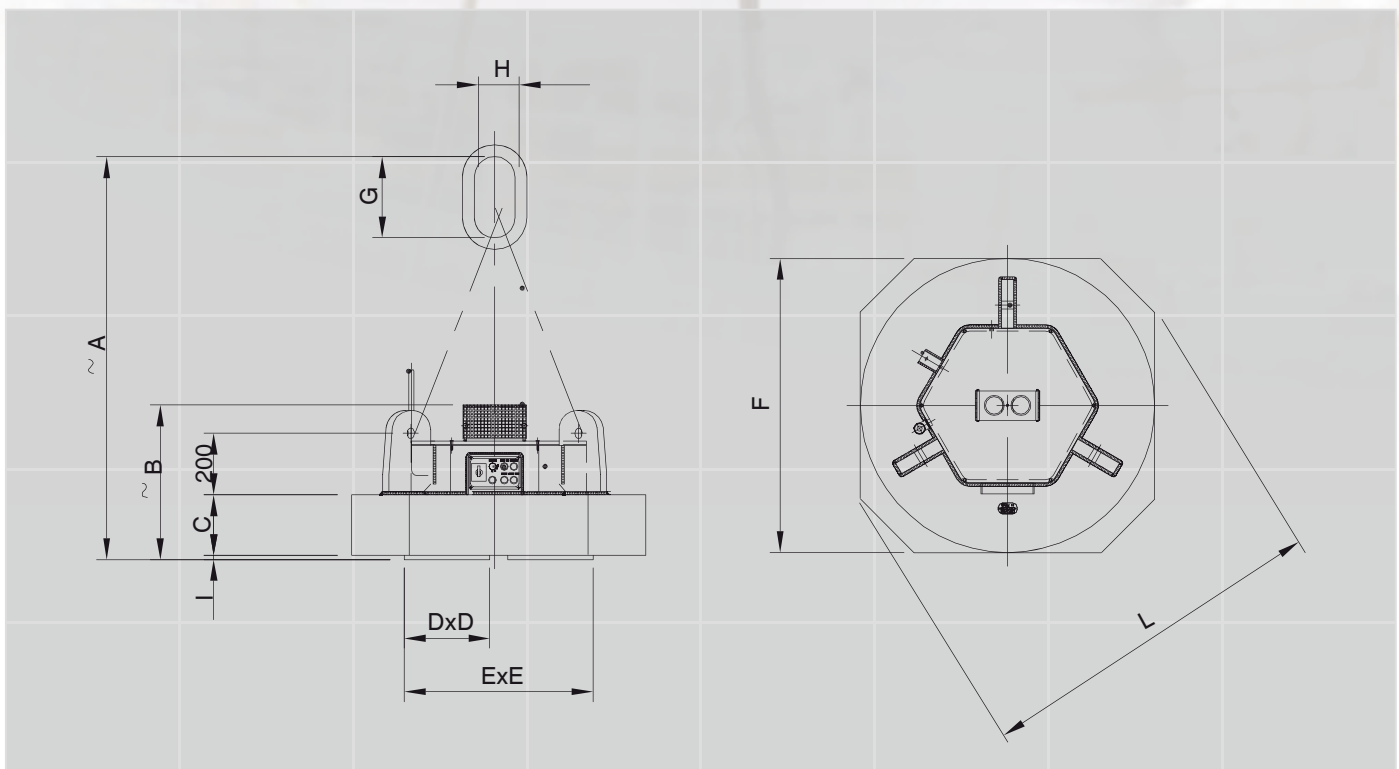

HPM

ELECTRO-PERMANENT PLATE HANDLING LIFTER



Features:

- Lifting plate with electro-permanent technology, cannot drop a load due to loss of power.
- Lift plates without slings chains or straps eliminating any associated damage.
- With radio remot control.
- HSS (Helmholtz safety system) prevents the De-mag while loads is suspended.
- Variable power pick up to de-stack plates safely.
- Hydraulic actuated variable size spreader beam increases safety, versatility and efficiency.
- Magnetic modules are selectable longitudinally and transversally to suit short or narrow plates.
- Test lift function insures safe load handling each and every time by insuring a minimum safety factor is guaranteed with each and every lift.

Applications

Single plate de-stacking capability down to 5mm thick plate.

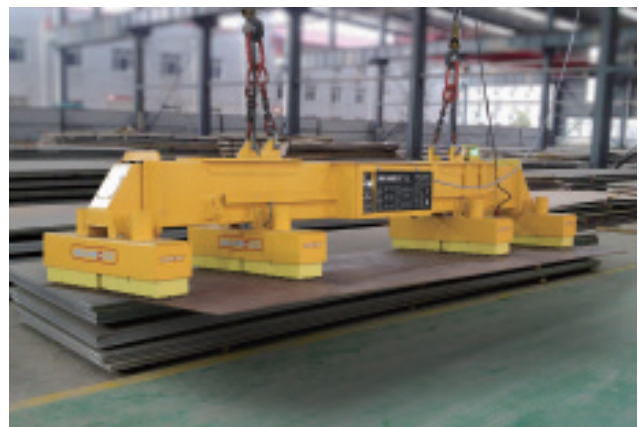
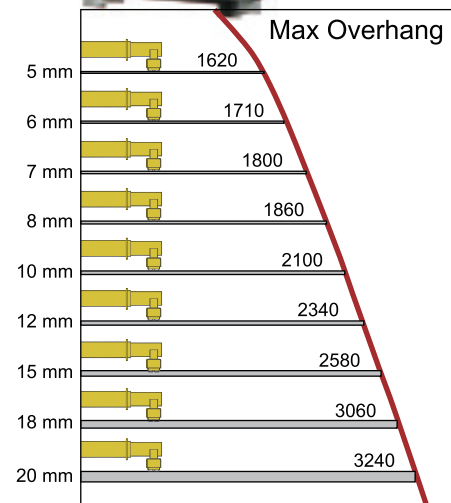

HPM

ELECTRO-PERMANENT PLATE HANDLING LIFTER

Load Capabilities mm (inch)

Model	Weight	Thickness	Length		Width		Rated lift capacity
		Min.	Min.	Max.	Min.	Max.	Max.
HPM 4/75	3600 kg/7920 lb	5 (0.20)	3000 (118.11)	12500 (492)	500 (19.69)	2500 (98.43)	7500 kg/16500 lb
HPM 4/100	3600 kg/7920 lb	5 (0.20)	3000 (118.11)	12500 (492)	500 (19.69)	3500 (137.80)	10000 kg/22000 lb
HPM 4/120	3600 kg/7920 lb	5 (0.20)	3000 (118.11)	12500 (492)	500 (19.69)	3500 (137.80)	12000 kg/26400 lb
HPM 4/140	3600 kg/7920 lb	8 (0.31)	3000 (118.11)	12500 (492)	500 (19.69)	3500 (137.80)	14000 kg/30800 lb
HPM 4/180	3600 kg/7920 lb	8 (0.31)	3000 (118.11)	12500 (492)	500 (19.69)	3500 (137.80)	18000 kg/39600 lb

HPM 4

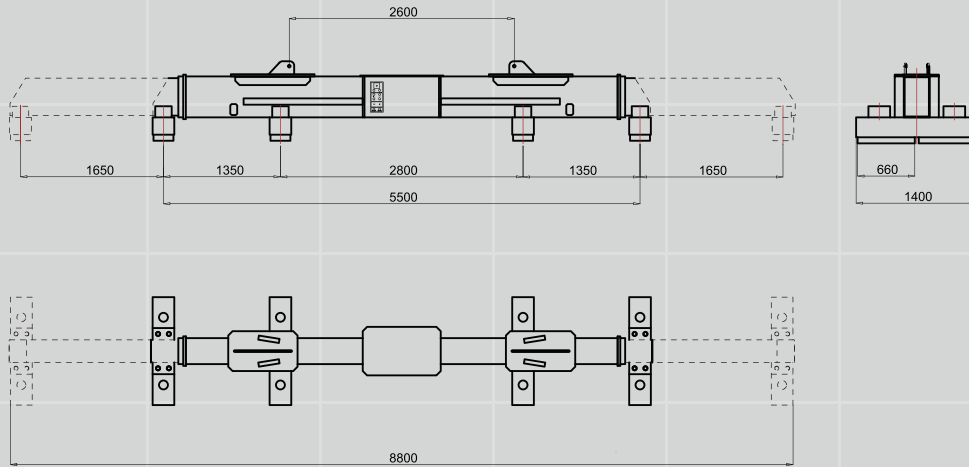

Model	Weight	Thickness	Length		Width		Rated lift capacity
		Min.	Min.	Max.	Min.	Max.	Max.
HPM 6/100	4800 kg/10560 lb	5 (0.20)	2800 (110.24)	16000 (629.92)	500 (19.69)	2500 (98.43)	10000 kg/22000 lb
HPM 6/140	4800 kg/10560 lb	5 (0.20)	2800 (110.24)	16000 (629.92)	500 (19.69)	3500 (137.80)	14000 kg/30800 lb
HPM 6/180	4800 kg/10560 lb	5 (0.20)	2800 (110.24)	16000 (629.92)	500 (19.69)	3500 (137.80)	18000 kg/39600 lb
HPM 6/200	4800 kg/10560 lb	8 (0.31)	2800 (110.24)	16000 (629.92)	500 (19.69)	3500 (137.80)	20000 kg/44000 lb
HPM 6/250	4800 kg/10560 lb	8 (0.31)	2800 (110.24)	16000 (629.92)	500 (19.69)	3500 (137.80)	25000 kg/55000 lb

HPM 6

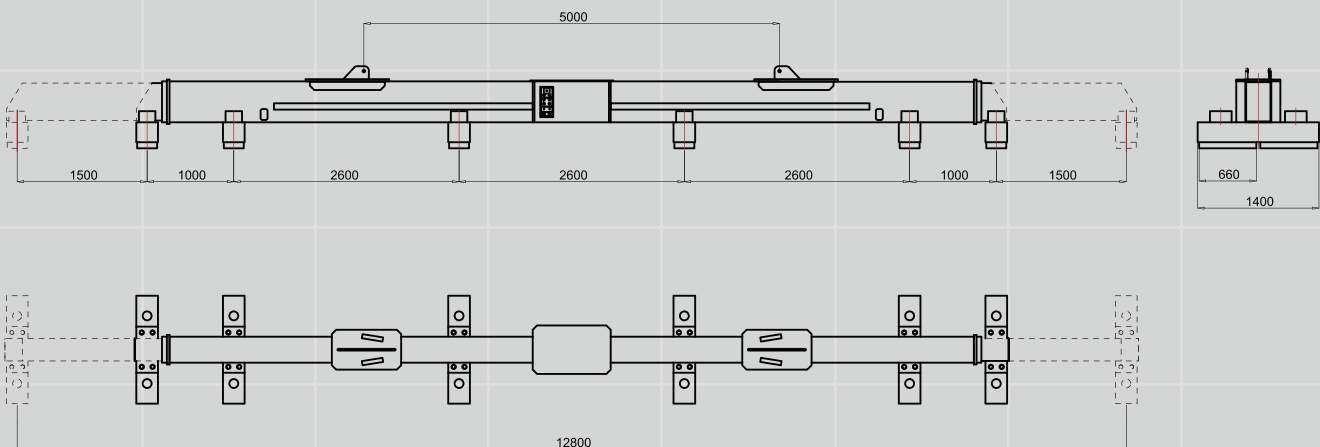

HPR

ELECTRO-PERMANENT ROUND STOCK HANDLING LIFTER



For handling finished or semi-finished round stock / pipe

HPR electro-permanent magnetic modules are the ideal answer for handling rounds and tanks with limited air gap.

- Excellent power to weight ratio
- Multi-pole powered magnetic circuit insures no residual magnetism and high performance with a low flux depth
- Maximum working load up to 10 Tons

Standard Operational Features:

- Adjustable power level for de-staking plates and slabs as needed
- Radio remote
- No residual magnetism
- Low flux depth
- Test lift function insures safe load handling each and every time by insuring a minimum safety factor is guaranteed with each and every lift
- Status lights
- Electro perm technology saves energy
- No moving parts to wear out
- On board controls for easy installation

Optional:

1. Removable poles shoes
2. Dual controls
3. Temperature sensor
4. Hi temp version available on request
5. DC power supply
6. Crane control interface
7. MSD sensor to check magnetic saturation

Standard Safety features:

- Electro-perm technology cannot drop a load due to loss of power
- Test lift sequence prevents unsafe loads due to air-gap, load geometry, or actual load composition from being handled
- Lifter status lights to insure the operator always knows the lifter status
- Radio remote keeps the operator a safe distance while operating the magnet
- Safety switch prevents de-mag unless the load is safely on the ground
- CSS sensor to insure controller and magnet are working properly
- Safe button for de-mag to insure accidental de-mag cannot be achieved

Applications

Steel service centers, Mold and die shop, Fabricators, Heat treating, steel mills, Steel warehouse



HPR

ELECTRO-PERMANENT ROUND STOCK HANDLING LIFTER

HPR-1500

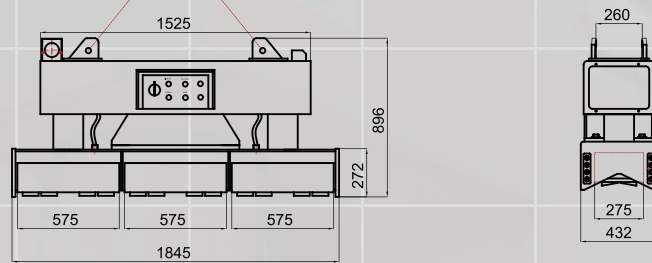

HPR-3000

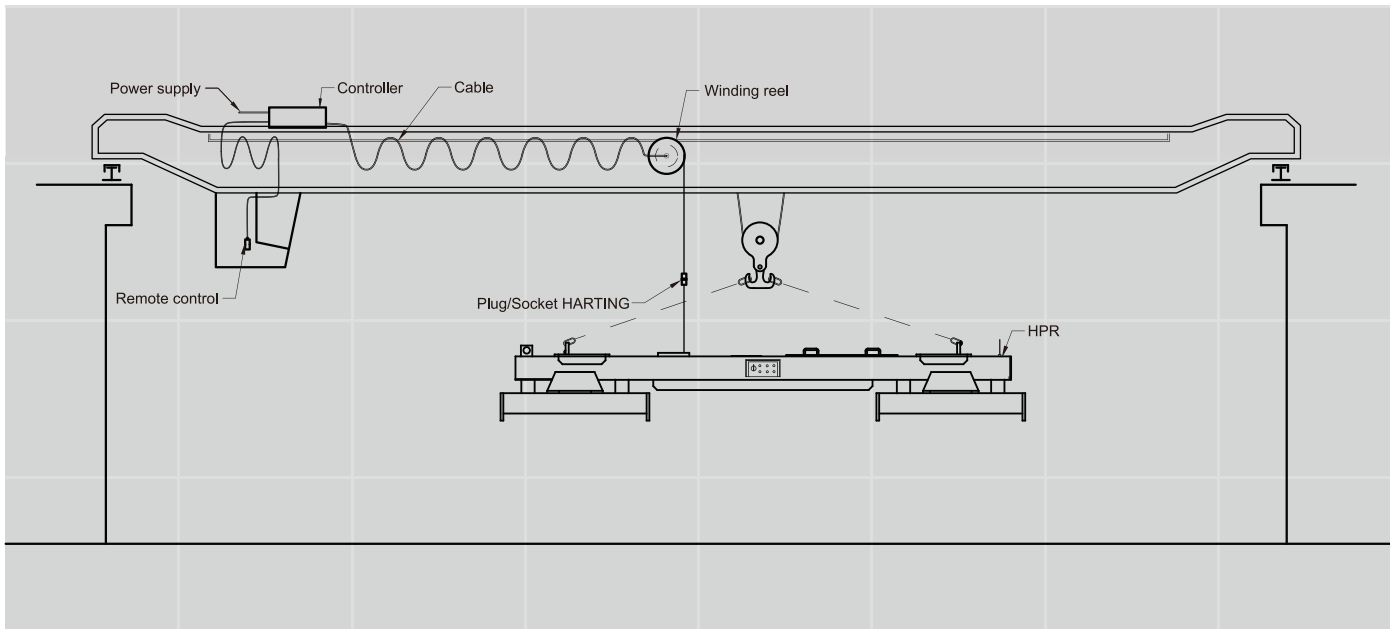
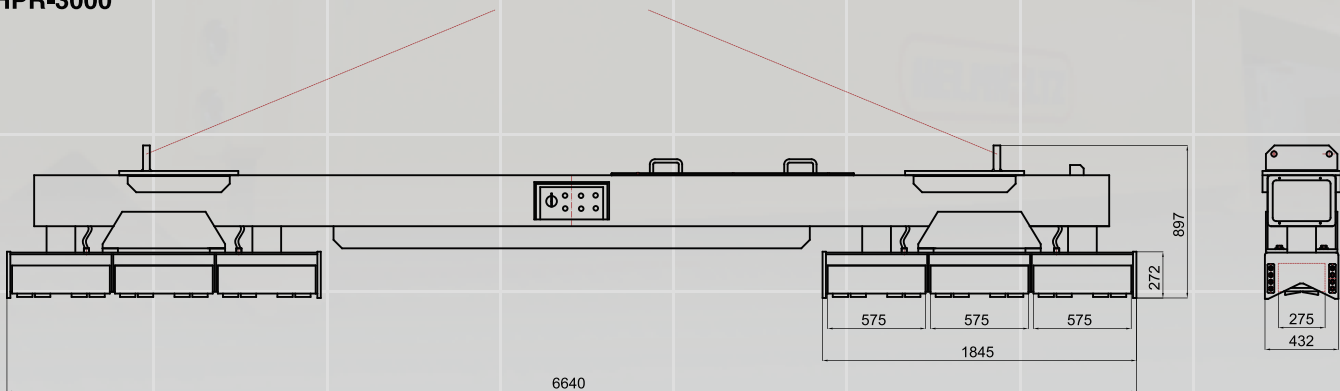

HPE

ELECTROMAGNETIC LIFTER

These magnets are compact, mobile, self-contained using a heavy duty 12 volt battery. Operating on this battery source they are free of restrictive cords and wires, They also have the added advantage of being useful in areas where electricity is not available.

Features

- Smart charger to prevent over charging or charging of a battery with a bad cell
- Audible Warning Alarm & Flashing Light indicates low battery
- Remote control keeps the operator a safe distance while operating the magnet.
- Safety switch prevents de-mag unless the load is safely on the ground



Applications

Steel service centers, Mold and die shop, Fabricators, Heat treating, steel mills, Steel warehouse



These versatile magnets are used in many areas of applications; handling of plates, die blocks, machined components, smooth castings and forgings. These battery powered magnets are extremely useful throughout any plant, shipping and receiving areas, storerooms, on cut-off saws, burning and welding tables, and with other machine tools such as grinders, shapers, drill presses and more.

Battery Powered magnets use a heavy-duty 12VDC battery and can be turned on and off using a touch pad mounted on the front of the magnet or a hand held I/R remote transmitter.

Dimensions

mm(inch)

Model	Size	Safe Working Load	Length	Width	Height to crane hook	Net weight	Ship weight
HPE	1300	1350 kg/3000 lb	414 (16.3)	218 (8.6)	559 (22)	86 kg / 190 lbs	91 kg / 200 lbs
HPE	2500	2500 kg/5500 lb	533 (21)	244 (9.6)	584 (23)	125 kg / 275 lbs	132 kg / 290 lbs
HPE	3600	3640 kg/8000 lb	1219 (48)	244 (9.6)	584 (23)	254 kg / 560 lbs	263 kg / 580 lbs
HPE	5000	5000 kg/11000 lb	1524 (60)	305 (12)	584 (23)	295 kg / 650 lbs	318 kg / 700 lbs

Batteries not included

PLN

PERMANENT LIFTER

permanent lifting magnet especially for small room space or very high frequency mag and demag

Features

- Suitable to lift plates and rounds
- Strong clamping force while small and compact in size
- Mag and demag switch mechanism can be handled easily as travel angle is small
- Switch mechanism can also prevent the accidental demag
- Large clamping area makes stable holding
- Lifting eye is replaceable which can be good for special application

Applications

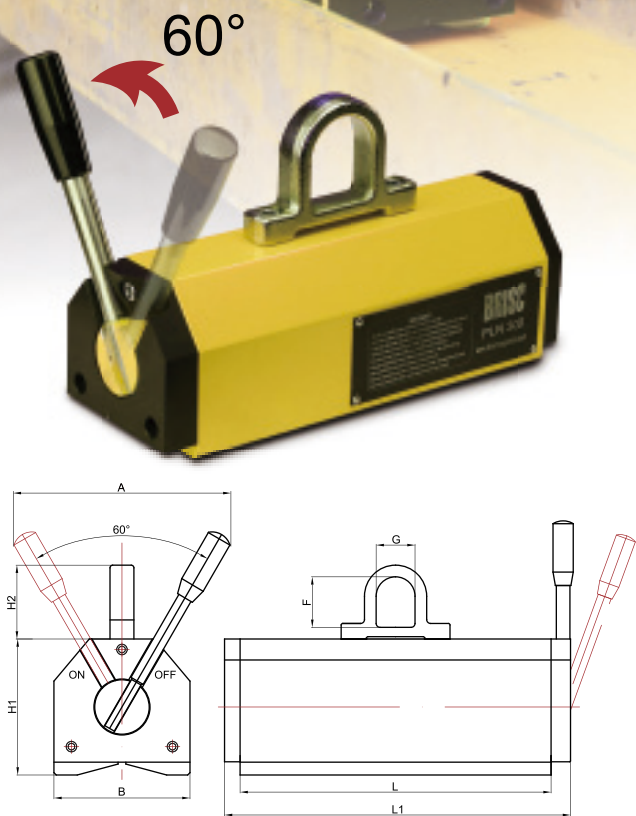

Specifications

mm(inch)

Model	Size	Safe Working Load	A	B	L	L1	H1	H2	F	G	Net Weight
PLN	150	150 kg / 330 lb	200 (7.87)	90 (3.54)	132 (5.2)	162 (6.38)	90 (3.54)	53 (2.09)	36 (1.42)	28 (1.1)	8 kg / 17.6 lb
PLN	300	300 kg / 660 lb	200 (7.87)	90 (3.54)	232 (9.13)	262 (10.31)	90 (3.54)	70 (2.76)	50 (1.97)	40 (1.57)	13 kg / 28.6 lb
PLN	600	600 kg / 1320 lb	280 (11.02)	136 (5.35)	270 (10.63)	300 (11.81)	136 (5.35)	95 (3.74)	65 (2.56)	50 (1.97)	36 kg / 79.2 lb
PLN	1000	1000 kg / 2200 lb	350 (13.78)	175 (6.89)	400 (15.75)	447 (17.60)	175 (6.89)	95 (3.74)	65 (2.56)	50 (1.97)	70 kg / 154 lb

Load Capabilities

mm(inch)

Model	Size	Load Plate Max	Plate Min Thickness	Plate Max Length	Load Round Max	Round Min Thickness	Round Max Diameter
PLN	150	150 kg / 330 lb	15 (0.59)	1000 (39.37)	60 kg / 132 lb	6 (0.24)	150 (5.9)
PLN	300	300 kg / 660 lb	20 (0.79)	2000 (78.74)	120 kg / 264 lb	10 (0.39)	180 (7.09)
PLN	600	600 kg / 1320 lb	25 (0.98)	2500 (98.43)	240 kg / 528 lb	15 (0.59)	250 (9.84)
PLN	1000	1000 kg / 2200 lb	40 (1.57)	3000 (118.11)	400 kg / 880 lb	25 (0.98)	280 (11.02)

SAFER

GENERAL PURPOSE PERMANENT LIFTER

For lifting ferromagnetic material with patented 1/2 power test position for safer lifting

Features

- Compact and light
- Suitable for flat and round material
- Maintenance free design
- Safety device prevent accidental deactivation
- Can be switched off by one hand only

Applications

Plate, bar, pipe, slab, block, mold, dies, castings and crop end material handling



The Patented 1/2 Power Test Lift

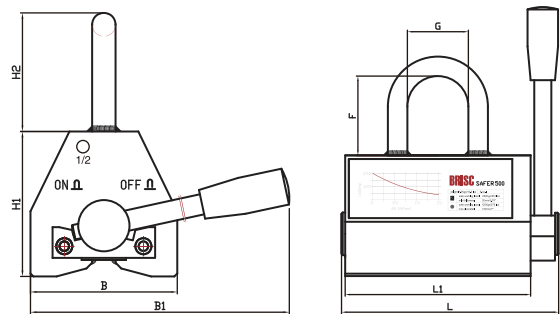

Specifications

mm(inch)

Model	Size	Safe Working Load	B	B1	L	L1	H1	H2	F	G	Net Weight
SAFER	150	150 kg/330 lb	60 (2.36)	162 (6.38)	114 (4.49)	93 (3.66)	69 (2.72)	50 (1.97)	40 (1.57)	30 (1.18)	4 kg/8.8 lb
SAFER	300	300 kg/660 lb	100 (3.94)	230 (9.06)	178 (7)	152 (5.98)	99 (3.9)	81 (3.19)	65 (2.56)	50 (1.97)	8 kg/17.6 lb
SAFER	600	600 kg/1320 lb	120 (4.72)	230 (9.06)	273 (10.75)	256 (10.08)	99 (3.9)	81 (3.19)	65 (2.56)	50 (1.97)	19 kg/41.8 lb
SAFER	1200	1200 kg/2640 lb	165 (6.5)	510 (20.08)	335 (13.2)	298 (11.7)	165 (6.5)	112 (4.41)	92 (3.62)	64 (2.52)	50 kg/110 lb
SAFER	2000	2000 kg/4400 lb	165 (6.5)	510 (20.08)	516 (20.31)	484 (19.06)	165 (6.5)	112 (4.41)	92 (3.62)	64 (2.52)	85 kg/187 lb
SAFER	3000	3000 kg/6600 lb	200 (7.87)	610 (24.02)	596 (23.46)	550 (21.65)	217 (8.54)	125 (4.92)	100 (3.94)	70 (2.76)	150 kg/330 lb
SAFER	5000	5000 kg/11000 lb	310 (12.20)	930 (36.61)	748 (29.45)	706 (27.80)	284 (11.18)	160 (6.3)	130 (5.12)	100 (3.94)	430 kg/946 lb

Load Capabilities

mm(inch)

Model	Size	Load Plate Max	Plate Min Thickness	Plate Max Length	Load Round Max	Round Min Thickness	Round Max Diameter	Round Max Length
SAFER	150	150 kg/330 lb	15 (0.59)	1000 (39.37)	60 kg/132 lb	10 (0.39)	150 (5.9)	1000 (39.4)
SAFER	300	300 kg/660 lb	20 (0.79)	1525 (60)	120 kg/264 lb	10 (0.39)	180 (7.09)	1525 (60)
SAFER	600	600 kg/1320 lb	25 (0.98)	2000 (78.74)	240 kg/528 lb	15 (0.59)	250 (9.84)	2000 (78)
SAFER	1200	1200 kg/2640 lb	40 (1.57)	3050 (120)	480 kg/1056 lb	25 (0.98)	280 (11.02)	3050 (120)
SAFER	2000	2000 kg/4400 lb	55 (2.17)	3050 (120)	800 kg/1760 lb	35 (1.38)	350 (13.78)	3050 (120)
SAFER	3000	3000 kg/6600 lb	70 (2.76)	3500 (137.8)	1200 kg/2640 lb	45 (1.77)	400 (15.75)	3500 (138)
SAFER	5000	5000 kg/11000 lb	85 (3.35)	4000 (157.48)	2000 kg/4400 lb	55 (2.17)	450 (17.7)	4000 (157)

SAFER-T

SAFER THIN PART MAGNET

With a lower flux depth than our general purpose lifter
 For safe handling of thin plates.
 Safely De-stack thin plates one at a time.
 Now with SAFER-T, you can handle thin plate easily
 and safely.

Features

- Special design allows controlled depth of flux
- High power with shallow flux depth, Specifically designed for de-stacking thin plates
- Still good on the thick plates
- "SAFER" test lift function



Applications

Plate down to 10mm(0.39"), bar, pipe, slab, block, mold, dies, castings and crop end material handling

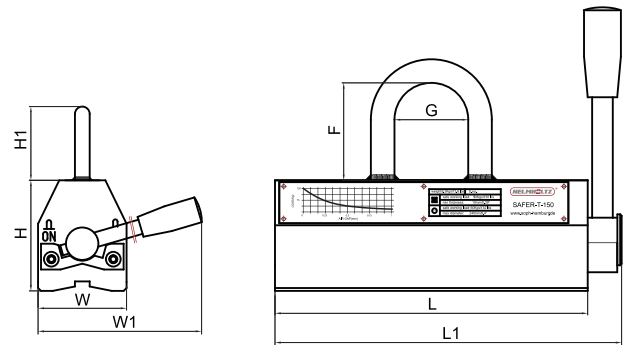
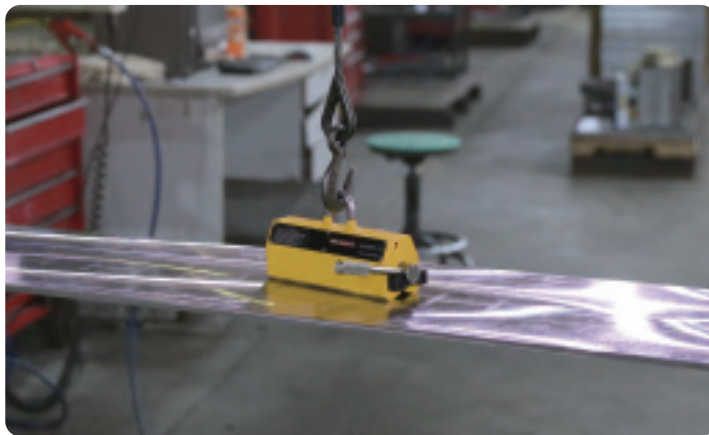

Specifications

mm(inch)

Model	Size	Width(W)	Length(L)	Height(H)	H1	W1	L1	G	F	Net Weight
SAFER-T	150	60 (2.36)	205 (8.07)	75 (2.95)	50 (1.97)	162 (6.38)	223 (8.78)	30 (1.18)	40 (1.57)	6.2 kg / 24 lb
SAFER-T	250	100 (3.94)	230 (9.06)	108 (4.25)	81 (3.19)	230 (9.06)	258 (10.16)	50 (1.97)	65 (2.56)	13 kg / 62 lb

Load Capabilities

mm(inch)

Model	Size	Flat load Max	Min Thickness	Max Length	Load Round Max	Round Min Diameter	Round Max Diameter
SAFER-T	150	150 kg/330 lb	10 (0.39)	1200 (47.24)	60 kg/132 lb	60 (2.36)	180 (7.09)
SAFER-T	250	250 kg/550 lb	12 (0.47)	1500 (59.06)	100 kg/220 lb	60 (2.36)	180 (7.09)

SAFER-R

DEEP V HIGH CAPACITY ROUND STOCK LIFTER

Increased round stock capacity with deeper V poles creating better surface contact for round stock and good versatility with flat stock when needed.

Safer R has a higher capacity on round stock compared to general purpose or thin system lifters.

Features

- Deeper V shape pole shoes than standard SAFER to ensure safer conditions on round stock
- Higher performance on rounds than general purpose lifters
- More stability on rounds
- Good flat stock capacity
- "SAFER" 1/2 Power test lift feature

Applications

Round or flat, the "safest" way to handle a load.

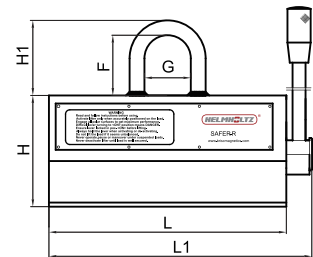
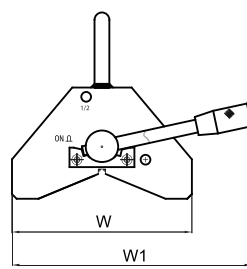

Specifications

mm(inch)

Model	Size	Width(W)	Length(L)	Height(H)	H1	W1	L1	G	F	Net Weight
SAFER-R	300	123 (4.84)	152 (5.98)	108 (4.25)	81 (3.19)	230 (9.06)	178 (7.01)	50 (1.97)	65 (2.56)	11 kg / 24 lb
SAFER-R	600	194 (7.64)	256 (10.08)	120 (4.72)	81 (3.19)	230 (9.06)	284 (11.18)	50 (1.97)	65 (2.56)	28 kg / 62 lb
SAFER-R	1200	280 (11.02)	316 (12.44)	185 (7.28)	112 (4.41)	315 (12.40)	344 (13.54)	64 (2.52)	92 (3.62)	90 kg / 198 lb
SAFER-R	2000	370 (14.57)	484 (19.06)	240 (9.45)	112 (4.41)	510 (20.08)	521 (20.51)	64 (2.52)	92 (3.62)	200 kg / 440 lb
SAFER-R	3000	440 (17.32)	550 (21.65)	285 (11.22)	125 (4.92)	610 (24.02)	596 (23.46)	70 (2.76)	100 (3.94)	350 kg / 770 lb

Load Capabilities

mm(inch)

Model	Size	Flat load Max	Min Thickness	Max Length	Load Round Max	Round Min Diameter	Round Max Diameter
SAFER-R	300	300 kg/660 lb	20 (0.79)	1525 (60)	150 kg/330 lb	60 (2.36)	200 (7.87)
SAFER-R	600	600 kg/1320 lb	25 (0.98)	2000 (78.74)	300 kg/660 lb	60 (2.36)	305 (12)
SAFER-R	1200	1200 kg/2640 lb	40 (1.57)	3050 (120)	500 kg/1100 lb	80 (3.15)	360 (14.17)
SAFER-R	2000	2000 kg/4400 lb	55 (2.17)	3050 (120)	1000 kg/2200 lb	80 (3.15)	460 (18.11)
SAFER-R	3000	3000 kg/6600 lb	70 (2.76)	3500 (137.8)	1500 kg/3300 lb	100 (3.94)	560 (22.05)

PAR

SAFER VERTICAL SYSTEM

PAR system is designed for the vertical handling of plates.

The typical application is loading / unloading a workpiece on a horizontal spindle milling machine. Can be used to flip parts over as needed in a safe manner using simple stalls is possible to fix the workpiece to the magnetic chuck from one side to other one, so as to work both faces.

PAR is easily adaptable to workpieces of different sizes, changing the position of locking pins.

PAR is available for SAFER 300 / 600.

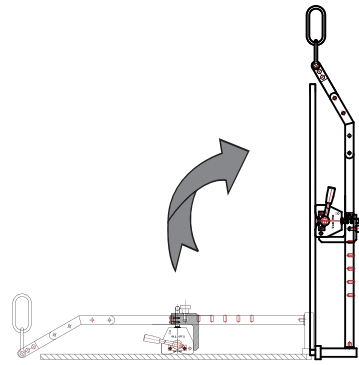
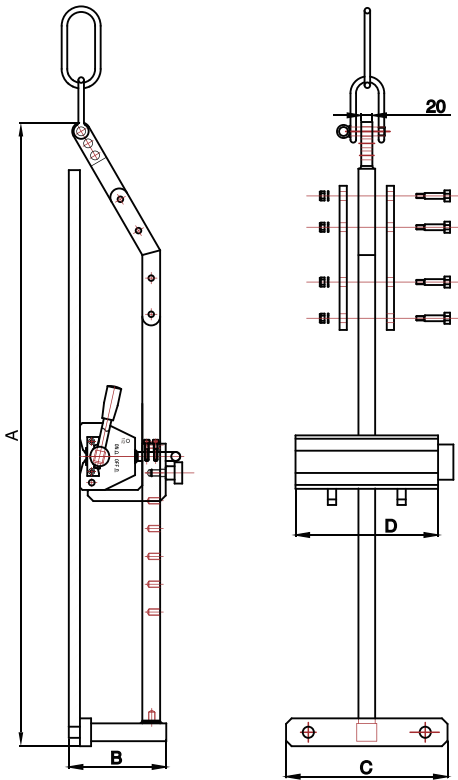
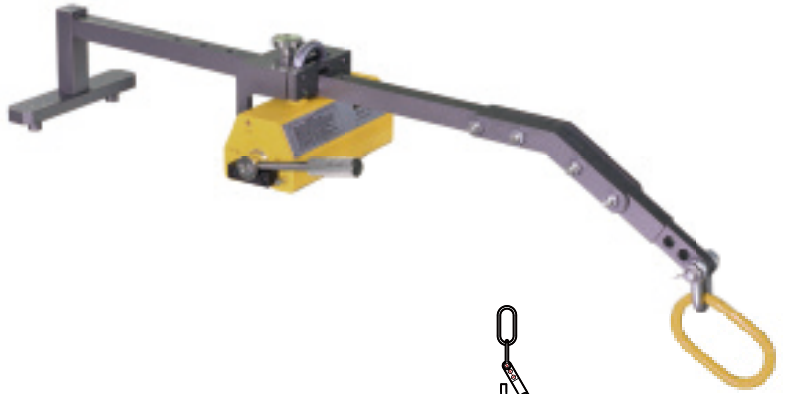

Dimensions

mm(inch)

With PAR	SAFER 300	SAFER 600
A	1121 (44.13)	1121 (44.13)
B	175 (6.89)	175 (6.89)
C	290 (11.42)	290 (11.42)
D	256 (10.08)	256 (10.08)
Weight	31 kg/68.2 lbs	42 kg/92.4 lbs

Load Capabilities

mm(inch)

With PAR	SAFER 300	SAFER 600
Load Max	300 kg / 660 lbs	600 kg / 1320 lbs
Max length plate	800 (31.50)	1000 (39.37)
Min length plate	300 (11.81)	300 (11.81)
Min thickness plate	4 (0.16)	6 (0.24)
Max width plate	550 (21.65)	700 (27.56)



SOPH provides a line of accessories for SAFER lifters to increase overall flexibility during use of horizontal and vertical material handling applications. The durable design makes them reliable over time with no required maintenance.

BLM

SAFER FIXED BEAM

The BLM spreader beam allows for the mounting of 2 SAFER lifters increasing the load handling characteristics without complicating the overall simplicity of the process.

BLM-1 handles loads up to 960 kgs and 3000mm while BLM-2 handles loads up to 1920kg and 3000mm in length.

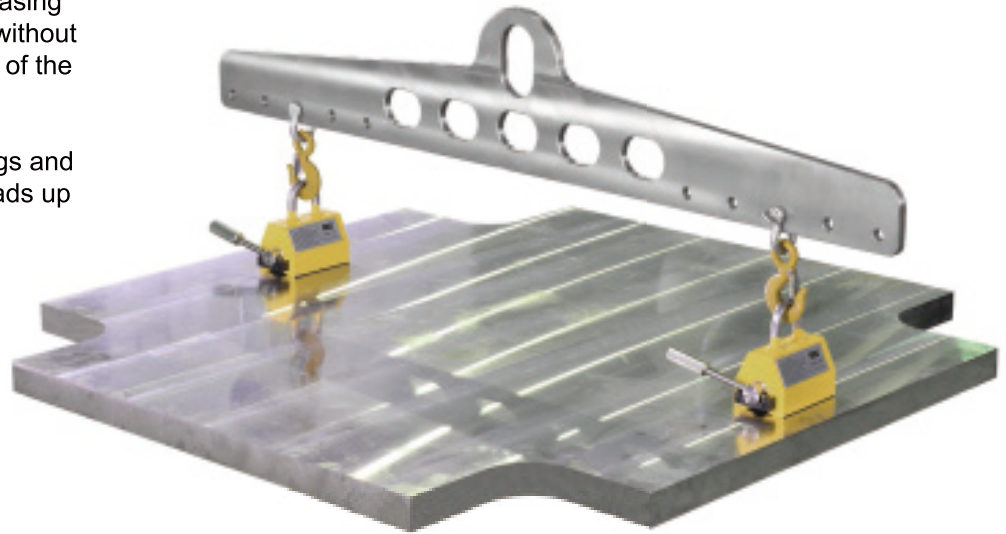

Dimensions mm(inch)

BLM-1

A	1680 (66.14)
B	300 (11.81)
C	130 (5.12)
D	15 (0.59)
Weight	37 kg/81.4 lbs

BLM-2

A	1900 (74.80)
B	415 (16.34)
C	160 (6.30)
D	20 (0.79)
Weight	75 kg/165 lbs

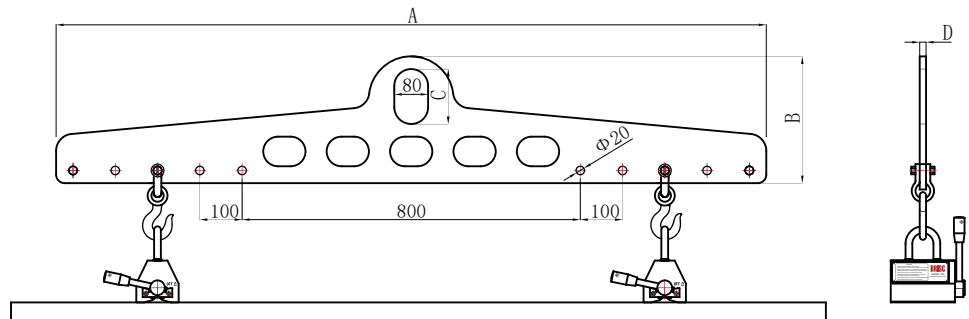

Load Capabilities mm(inch)

BLM-1

in combination with:	Load	Plates		Rounds	
		Max Length	Max Width	Load	Max Length
2 x SAFER-150	240 kg/528 lbs	1525 (60)	1015 (40)	100 kg/440 lbs	1525 (60)
2 x SAFER-300	480 kg/990 lbs	3050 (120)	1525 (60)	200 kg/440 lbs	3050 (120)
2 x SAFER-600	960 kg/2112 lbs	3050 (120)	1525 (60)	400 kg/880 lbs	3050 (120)

BLM-2

in combination with:	Load	Plates		Rounds	
		Max Length	Max Width	Load	Max Length
2 x SAFER-600	960 kg/2112 lbs	3050 (120)	1525 (60)	400 kg/880 lbs	3050 (120)
2 x SAFER-1200	1920 kg/4224 lbs	3050 (120)	1525 (60)	750 kg/1650 lbs	3050 (120)

Features

- Powerful permanent lifting magnet with pneumatic activation
- V-shaped pole shoes for handling both flat and round components
- Removable lift eye, for automation applications
- Sensor to detect the ON and OFF position available on request

Applications

- Handling of flat and round material
- Loading and unloading of machine tools
- End of arm tooling
- Any application where remote activation is required

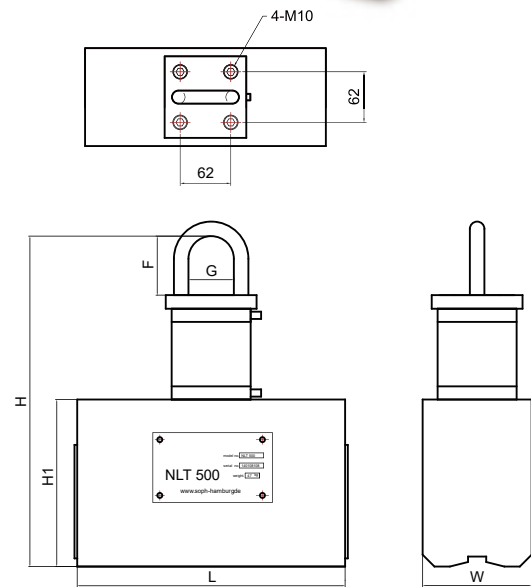
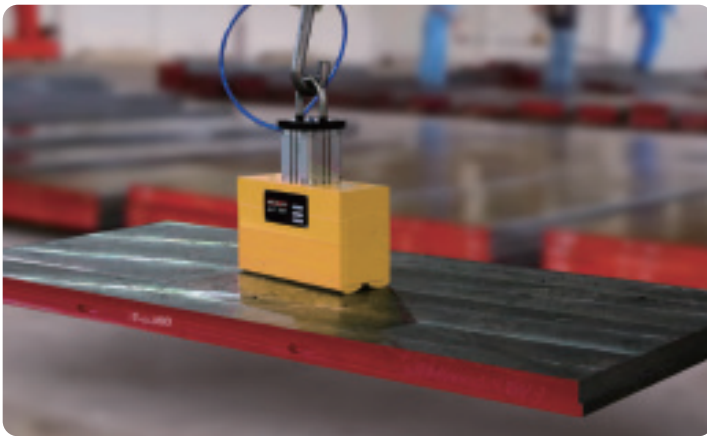

Specifications

mm(inch)

Model	Size	Width(W)	Length(L)	Height(H)	H1	G	F	Net Weight	Operating
NLT	250	120(4.72)	152 (5.98)	185 (7.28)	100 kg/220 lb	50 (1.97)	65 (2.56)	25 kg / 55 lb	80 PSI
NLT	500	120(4.72)	296 (11.65)	185 (7.28)	200 kg/440 lb	50 (1.97)	65 (2.56)	47 kg / 103 lb	80 PSI

Load Capabilities

mm(inch)

Model	Size	Flat load Max	Min Thickness	Max Length	Load Round Max	Round Min Diameter	Round Max Diameter
NLT	250	250 kg/550 lb	20 (0.79)	1500 (59.06)	100 kg/220 lb	60 (2.36)	200 (7.87)
NLT	500	500 kg/1100 lb	20 (0.79)	2000 (78.74)	200 kg/440 lb	60 (2.36)	200 (7.87)



© 1998 - 2023, SOPH GmbH, Hamburg, Germany

Copyright

All text, drawings, photos and product illustrations are subject to copyright and are the property of SOPH GmbH

Technical Changes

The data and illustrations in this catalogue are not binding and only provide an approximate description. We reserve the right to make changes to the product delivered compared with the data and illustrations in this catalogue, e.g. in respect of technical data, design, fittings, material and external appearance.

SOPH GmbH

Im Löwenthal 4, 55268 Nieder-Olm, Germany

Tel: +49-40-6094-63670 Fax: +49-40-6094-63679 info@soph-gmbh.de

SOPH Inc

195 South Alloy Dr. Fenton MI 48430

Tel: +1-810-750-1120 Fax: +1-810-750-1141 info@soph-inc.com

SOPH Ltd

Building 3, No.6 Xin Zhong Rd, Haining 314400

Tel: +86-0573-89262865 Fax: +86-0573-89262863 info@soph-ltd.com www.helmholtz-magnet.com